



FIRE & ICE MODEL: CH-7/12.5

230 Volt 1 Phase	
FLA	-
MCA	-
MOC	-

230 Volt 3 Phase	
FLA	41
MCA	52
MOC	60

460 Volt 3 Phase	
FLA	18
MCA	23
MOC	25

Dimensions	34"W x 61"L x 54"H
Frame	Powder Coated Steel
Housing	Stainless Steel
Tank	50 Gallon Stainless Steel
Compressor HP	7
Condenser	Air-Cooled
Glycol Pump HP	1.5
GPM @ 25 PSI	40
Connection Size	0.75" Brass Quick Connects (x5)
Heat Exchanger	Stainless Steel Brazed Plate
Controls	Single Stage Digital

Heater kW	12.5
Electrical Enclosure	NEMA 3R
Shipping Weight	1350 lbs
Decibels @ 10'	65
Refrigerant	R404a
Cooling (Btu/H) ¹	51,046
Heating (Btu/H)	42,700

¹ Cooling capacity using 30 °F glycol at 90 °F ambient

Fire & Ice package consists of the following:

- Complete refrigeration circuit
- Air-cooled condenser
- Glycol pump
- Fluid bypass valve
- Freeze stat safety switch
- Digital temperature controller
- All insulated copper piping
- Stainless steel housing
- Powder coated steel frame
- Insulated stainless steel glycol reservoir
- Low watt density heating element specifically designed for glycol
- Engineered high efficiency heat exchanger for maximum energy savings
- Heavy duty rubber-on-steel casters for easy portability
- Brass quick connects for temperature control of up to 5 tanks at once without loss of glycol
- Complete set of 20 ft. glycol hoses and 25 ft. power cord
- ETL (UL508) listed complete control panel with single point electrical connection, breakers, starters & safety switches
- Louvered stainless steel access panels for easy service & maintenance
- Factory run tested and fully charged with refrigerant

2 Year Parts and 1 Year Labor Warranty

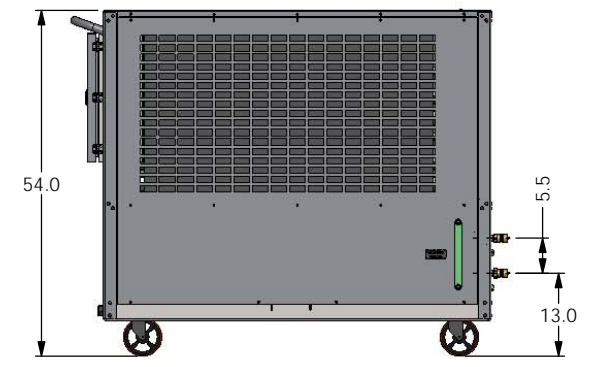
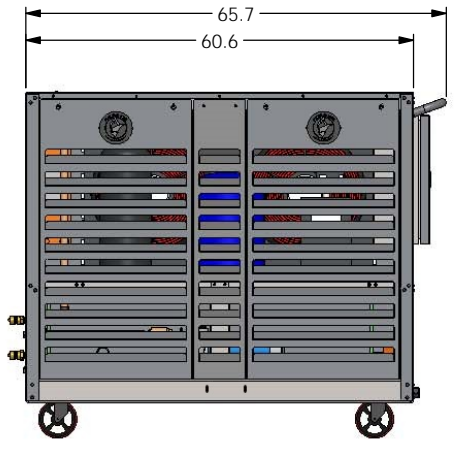
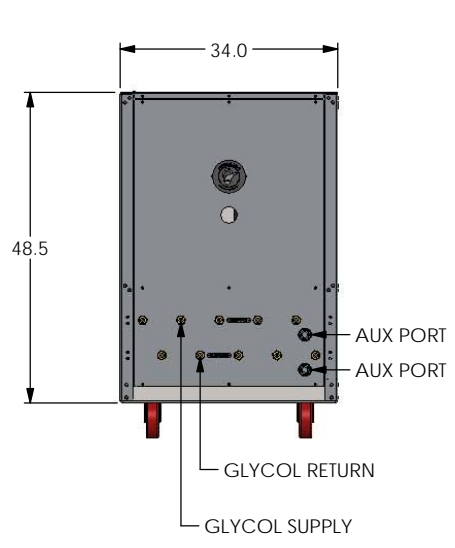
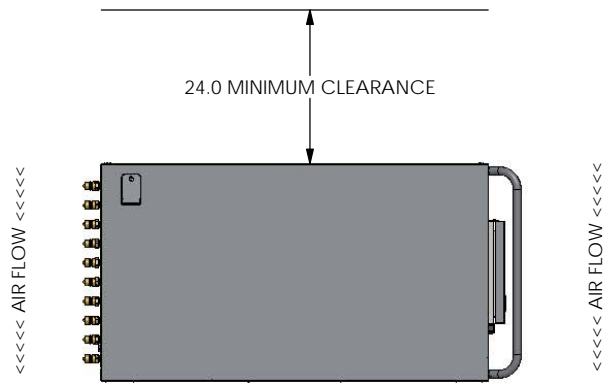

CH - 5/10.5	CH - 7/12.5	 G&D CHILLERS
PORTABLE CHILLER & HEATER		COMMITTED TO COLD ○ EST 1993 ○ <small>760 BAILEY HILL ROAD EUGENE, OR 97402 - TEL (541) 345-3903 (800) 555-0973</small>