



CHILLER MODEL: GD-80T-4

230 Volt 1 Phase	
FLA	-
MCA	-
MOC	-

230 Volt 3 Phase	
FLA	427
MCA	450
MOC	540

460 Volt 3 Phase	
FLA	207
MCA	218
MOC	260

Dimensions ¹	91"W x 167"L x 113"H
Frame	Powder Coated Steel
Housing	Powder Coated Aluminum
Tank	600 Gallon Stainless Steel
Compressor	Tandem Scroll (x2)
Condenser	Air-Cooled Vertical Discharge
Process Pump HP	7.5
GPM @ 25 PSI	230
Connection Size	3" CTS Flange
Chiller Pump HP	5
Heat Exchanger	Stainless Steel Brazed Plate
Controls	Microprocessor w/ Comm.

Electrical Enclosure	NEMA 3R
Operating Weight	13,400 lbs (Approx.)
Decibels @ 10'	71
Refrigerant	R410a

Cooling Capacity based on Ambient Temperature²

T _{ambient} (°F)	Btu/H	kW
90	992,400	290.8
100	928,400	272.1

¹ Dimensions accurate for package chiller, remote condenser options will vary

² Capacities at 40 °F leaving fluid temperature

Chiller package consists of the following:

- Complete refrigeration circuit
- Air-cooled condenser
- Process pump with VFD
- Chiller pump
- Fluid bypass valve
- Freeze stat safety switch
- All insulated copper piping
- Powder coated steel frame
- Powder coated aluminum housing
- Two sets of tandem scroll compressors for maximum efficiency & redundancy
- Engineered high efficiency heat exchangers
- Insulated stainless steel glycol reservoir with baffle plate
- Microprocessor controller with communication
- ETL (UL508) listed complete control panel with single point electrical connection, breakers, starters & safety switches
- CTS flange glycol supply and return connections
- Louvered aluminum access panels for easy service & maintenance
- Factory run tested and fully charged with refrigerant

2 Year Parts and 1 Year Labor Warranty

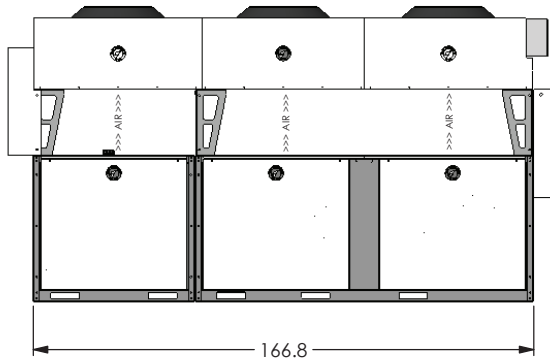
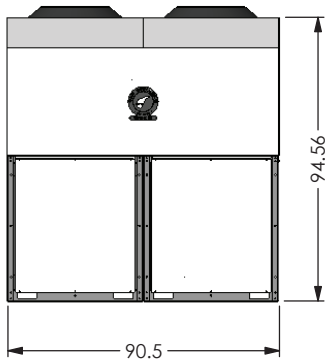
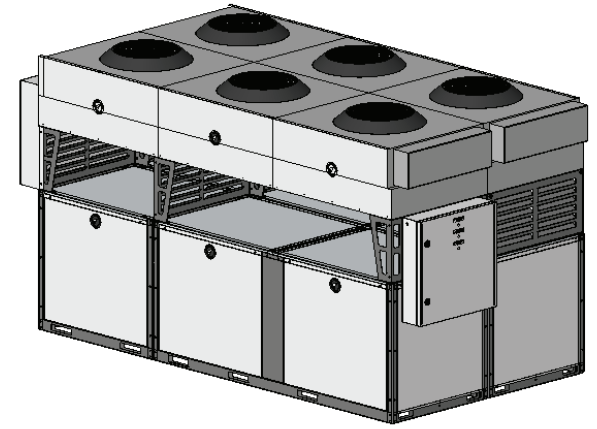
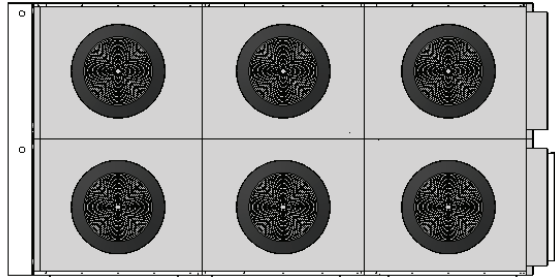

CONTROL
PANEL

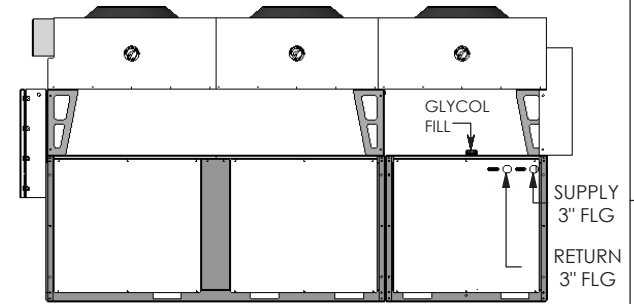
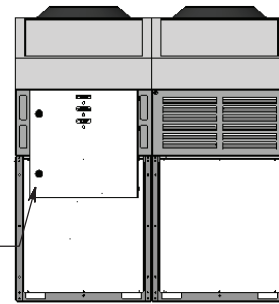

GD-80T-4 STATIONARY CHILLER



G&D CHILLERS

COMMITTED TO COLD

◦ EST 1993 ◦

760 BAILEY HILL ROAD EUGENE, OR 97402 • TEL (541) 345-3903 (800) 555-0973