



CHILLER MODEL: GD-13.5H

230 Volt 1 Phase	
FLA	-
MCA	-
MOC	-

230 Volt 3 Phase	
FLA	57
MCA	69
MOC	113

460 Volt 3 Phase	
FLA	30
MCA	40
MOC	60

Dimensions ¹	48"W x 73"L x 61"H
Frame	Powder Coated Steel
Housing	Powder Coated Aluminum
Tank	110 Gallon Stainless Steel
Compressor	13.5 HP
Condenser	Air-Cooled Microchannel
Glycol Pump	2 HP
Process Flow	65 GPM @ 25 PSI
Connection Size	1.5" FPT
Heat Exchanger	Stainless Steel Brazed Plate
Controls	Microprocessor w/ Comm.

Electrical Enclosure	NEMA 3R
Ship/Operating Weight	1450/2250 lbs
Decibels @ 10'	68 dBA
Refrigerant	R448A

Cooling Capacity by Leaving Fluid Temperature ²

LFT	Btu/H	kW
20 °F	78,500	23.0
30 °F	96,000	28.1
40 °F	115,000	33.7

1. Package chiller dimensions, remote condenser options will vary

2. All capacities at 90 °F ambient

3. VFD available upon request

4. Specifications subject to change without notice

Chiller package consists of the following:

- Complete refrigeration circuit
- Air-cooled microchannel condenser
- Glycol pump³
- Fluid bypass valve
- All insulated copper piping
- Powder coated steel frame
- Powder coated aluminum housing
- Insulated stainless steel glycol reservoir
- Engineered high efficiency heat exchanger for maximum energy savings
- Microprocessor controller with communication capabilities
- ETL (UL508) listed complete control panel with single point electrical connection, breakers, starters & safety switches
- Brass ball valves for supply and return glycol connections
- Louvered aluminum access panels for easy service & maintenance
- Factory run tested and fully charged with refrigerant

2 Years Parts and 1 Year Labor Warranty

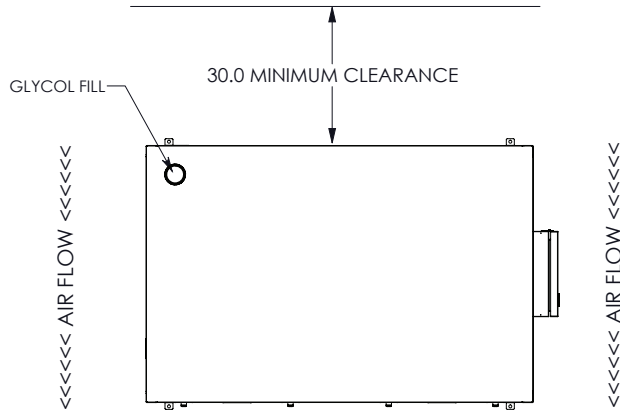

EXHAUST SIDE: DO NOT BLOCK / NO OBSTRUCTION

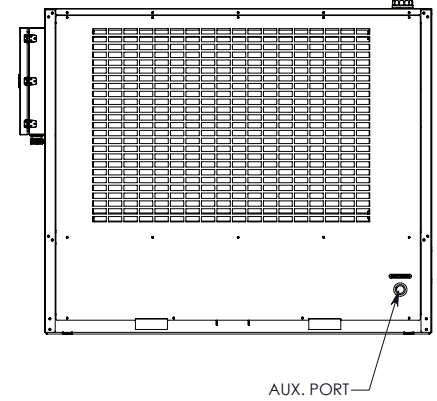
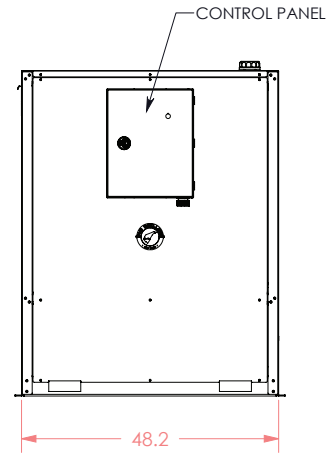
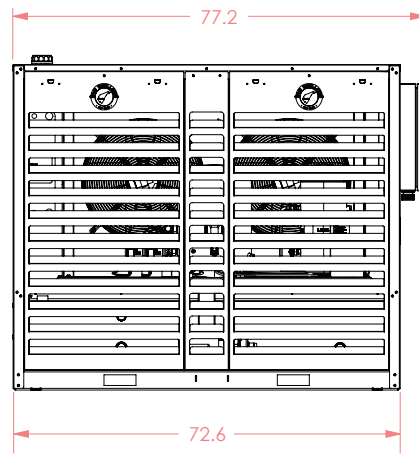
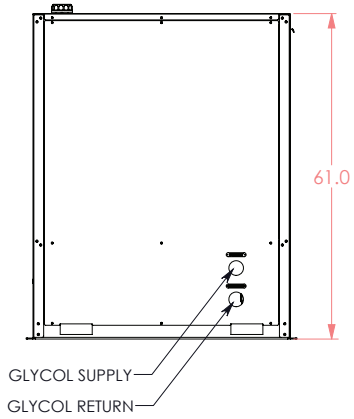
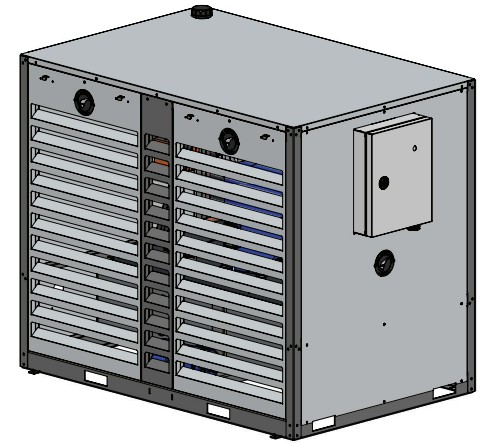

GD-10H / 13.5H STATIONARY CHILLER



G&D CHILLERS

COMMITTED TO COLD

◦ EST 1993 ◦

760 BAILEY HILL RD, EUGENE, OR 97402 - TEL (541) 345-3903 (800) 555-0973