



CHILLER MODEL: GD-20H

230 Volt 1 Phase	
FLA	-
MCA	-
MOC	-

230 Volt 3 Phase	
FLA	101
MCA	110
MOC	145

460 Volt 3 Phase	
FLA	52
MCA	55
MOC	72

Dimensions ¹	48"W x 120"L x 87"H
Frame	Powder Coated Steel
Housing	Powder Coated Aluminum
Tank	230 Gallon Crosslinked Poly (PEX)
Compressor HP	10 (x2)
Condenser	Air-Cooled
Process Pump HP	5
GPM @ 25 PSI	150
Connection Size	2" CTS Flange
Chiller Pump HP	1.5
Heat Exchanger	Stainless Steel Brazed Plate
Controls	Multi Stage Digital

Electrical Enclosure	NEMA 3R
Ship/Operating Weight	2450/4450 lbs
Decibels @ 10'	68
Refrigerant	R404a

Cooling Capacity by Leaving Fluid Temperature ²

LFT	Btu/H	kW
20 °F	128,436	37.6
30 °F	158,744	46.5
40 °F	192,990	56.6

1. Package chiller dimensions, remote condenser options will vary
2. All capacities at 90 °F ambient
3. VFD available upon request
4. Specifications subject to change without notice

Chiller package consists of the following:

- Two complete refrigeration circuits
- Air-cooled condenser
- Process pump³
- Chiller pump
- Fluid bypass valve
- Freeze stat safety switch
- All insulated copper piping
- Powder coated steel frame
- Powder coated aluminum housing
- Digital temperature controller with alternating relay for equal runtime of each compressor
- Engineered high efficiency heat exchanger for maximum energy savings
- Insulated crosslinked polyethylene (PEX) glycol reservoir
- ETL (UL508) listed complete control panel with single point electrical connection, breakers, starters & safety switches
- CTS flange glycol supply and return connections
- Louvered aluminum access panels for easy service & maintenance
- Factory run tested and fully charged with refrigerant

2 Year Parts and 1 Year Labor Warranty

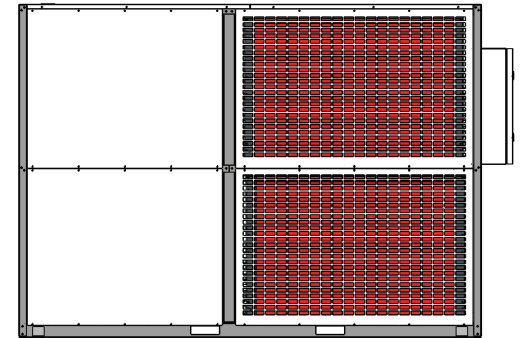
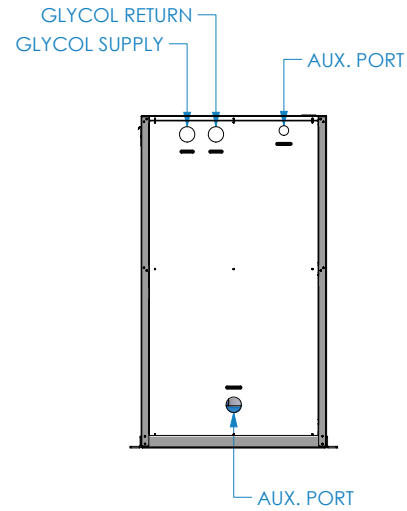
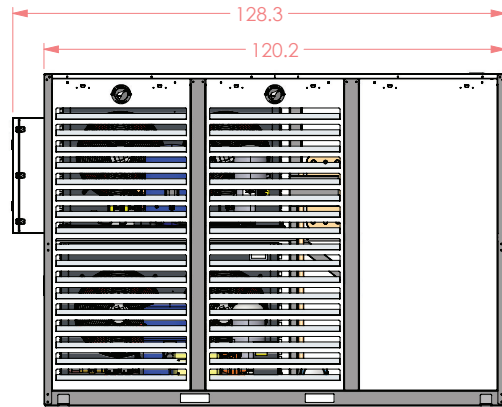
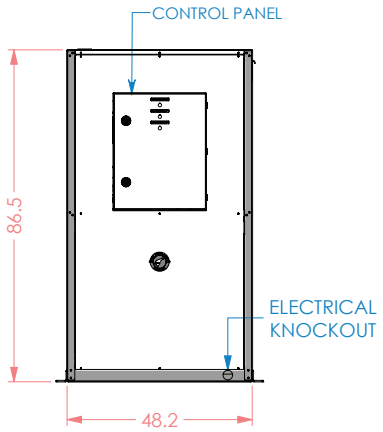
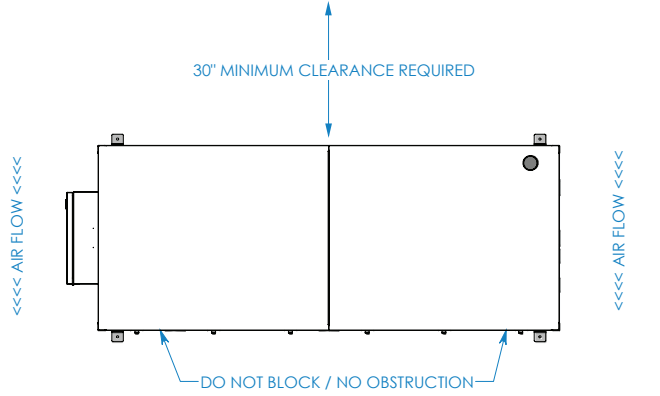
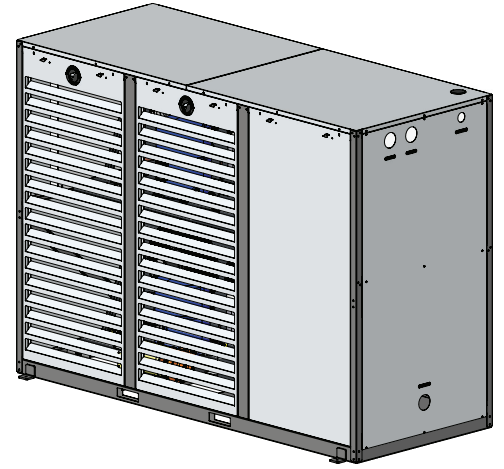

GD-20H/27H

STATIONARY CHILLER



G&D CHILLERS

COMMITTED TO COLD

o EST 1993 o

760 BAILEY HILL ROAD EUGENE, OR 97402 - TEL (541) 345-3903 (800) 555-0973