



## CHILLER MODEL: GD-5H

208-240 Volt 1 Phase	
FLA	48
MCA	56
MOC	90

208-240 Volt 3 Phase	
FLA	33
MCA	38
MOC	58

460-480 Volt 3 Phase	
FLA	14
MCA	17
MOC	26

Dimensions <sup>1</sup>	34"W x 61"L x 50"H
Frame	Powder Coated Steel
Housing	Powder Coated Aluminum
Tank	60 Gallon Stainless Steel
Compressor HP	5
Condenser	Air-Cooled
Glycol Pump HP	1.5
GPM @ 25 PSI	40
Connection Size	1" FPT
Heat Exchanger	Stainless Steel Brazed Plate
Controls	Single Stage Digital

Electrical Enclosure	NEMA 3R
Shipping Weight	1200 lbs
Decibels @ 10'	65
Refrigerant	R404a

### *Cooling Capacity by Leaving Fluid Temperature<sup>2</sup>*

LFT	Btu/H	kW
20 °F	32,717	9.6
30 °F	40,850	12.0
40 °F	49,965	14.6

<sup>1</sup>Dimensions accurate for package chiller, remote condenser options will vary

<sup>2</sup>All capacities at 90 °F ambient

<sup>3</sup>VFD available upon request

### *Chiller package consists of the following:*

- Complete refrigeration circuit
- Air-cooled condenser
- Glycol pump<sup>3</sup>
- Fluid bypass valve
- All insulated copper piping
- Powder coated steel frame
- Powder coated aluminum housing
- Insulated stainless steel glycol reservoir
- Engineered high efficiency heat exchanger for maximum energy savings
- Digital temperature controller
- ETL (UL508) listed complete control panel with single point electrical connection, breakers, starters & safety switches
- Brass ball valves for supply and return glycol connections
- Louvered aluminum access panels for easy service & maintenance
- Factory run tested and fully charged with refrigerant

**2 Year Parts and 1 Year Labor Warranty**

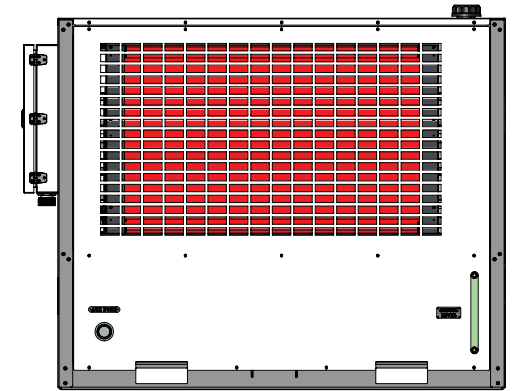
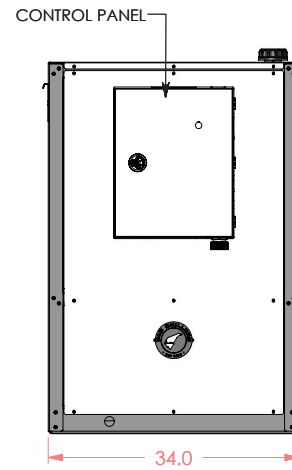
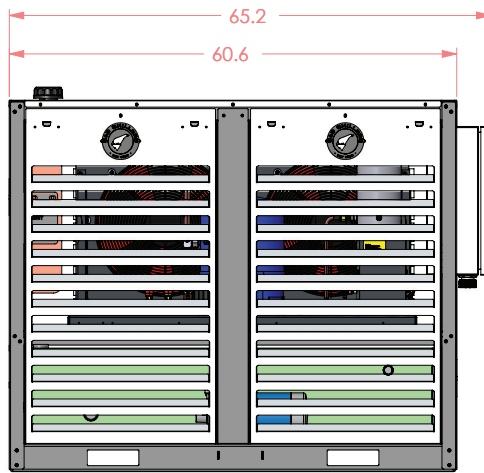
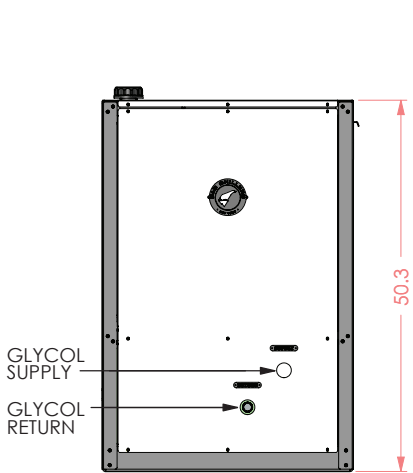
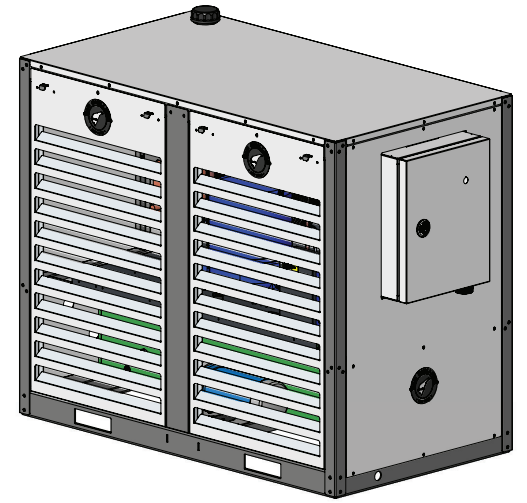
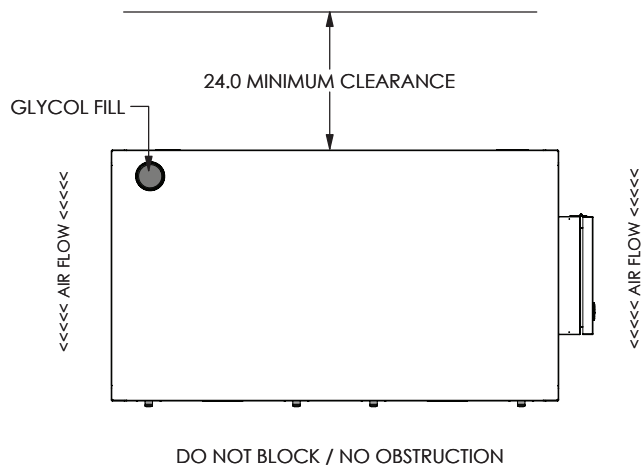

# GD-5H/7H STATIONARY CHILLER

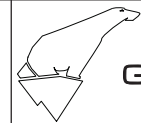

**G&D CHILLERS**

COMMITTED TO COLD

◦ EST 1993 ◦

760 BAILEY HILL ROAD EUGENE, OR 97402 - TEL (541) 345-3903 (800) 555-0973