



CHILLER MODEL: GD-7H

230 Volt 1 Phase	
FLA	-
MCA	-
MOC	-

230 Volt 3 Phase	
FLA	36
MCA	43
MOC	69

460 Volt 3 Phase	
FLA	17
MCA	20
MOC	31

Dimensions ¹	34"W x 61"L x 50"H
Frame	Powder Coated Steel
Housing	Powder Coated Aluminum
Tank	60 Gallon Stainless Steel
Compressor	7 HP
Condenser	Air-Cooled Microchannel
Glycol Pump	1.5 HP
Process Flow	40 GPM @ 25 PSI
Connection Size	1" FPT
Heat Exchanger	Stainless Steel Brazed Plate
Controls	Microprocessor w/ Comm.

Electrical Enclosure	NEMA 3R
Ship/Operating Weight	1100/1450 lbs
Decibels @ 10'	65 dBA
Refrigerant	R448A

Cooling Capacity by Leaving Fluid Temperature²

LFT	Btu/H	kW
20 °F	41,700	12.2
30 °F	51,700	15.2
40 °F	62,900	18.4

1. Package chiller dimensions, remote condenser options will vary

2. All capacities at 90 °F ambient

3. VFD available upon request

4. Specifications subject to change without notice

Chiller package consists of the following:

- Complete refrigeration circuit
- Air-cooled microchannel condenser
- Glycol pump³
- Fluid bypass valve
- All insulated copper piping
- Powder coated steel frame
- Powder coated aluminum housing
- Insulated stainless steel glycol reservoir
- Engineered high efficiency heat exchanger for maximum energy savings
- Microprocessor controller with communication capabilities
- ETL (UL508) listed complete control panel with single point electrical connection, breakers, starters & safety switches
- Brass ball valves for supply and return glycol connections
- Louvered aluminum access panels for easy service & maintenance
- Factory run tested and fully charged with refrigerant

2 Years Parts and 1 Year Labor Warranty

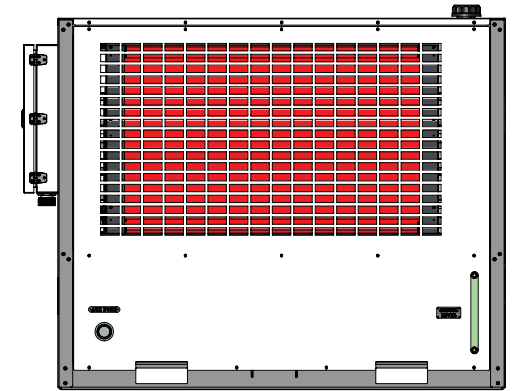
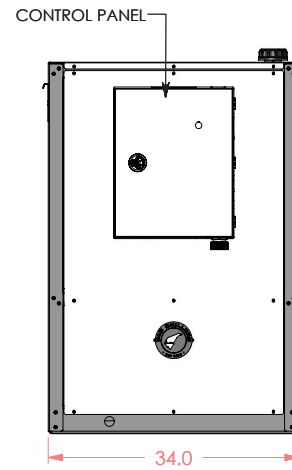
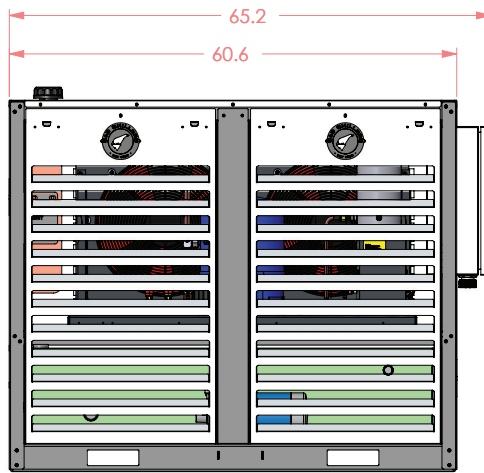
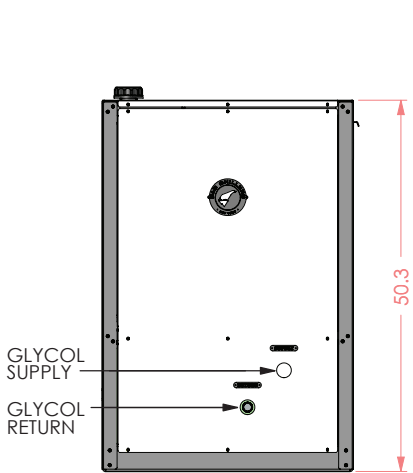
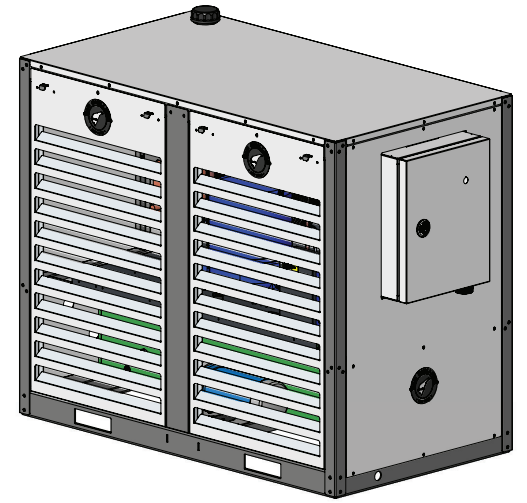
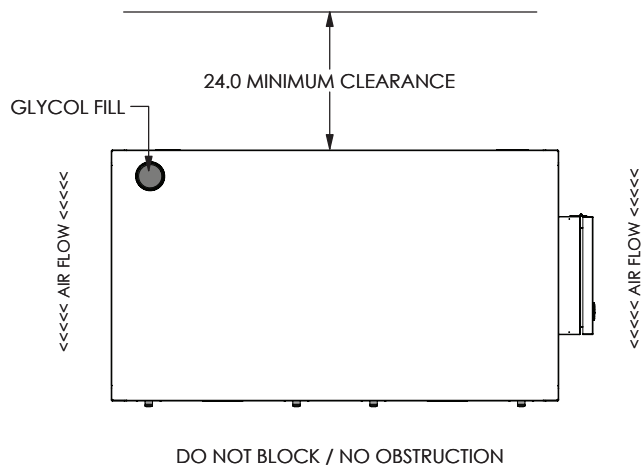

GD-5H/7H STATIONARY CHILLER

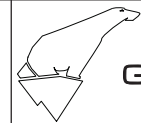

G&D CHILLERS

COMMITTED TO COLD

◦ EST 1993 ◦

760 BAILEY HILL ROAD EUGENE, OR 97402 - TEL (541) 345-3903 (800) 555-0973