



## CHILLER MODEL: GD-20H-EM

230 Volt 1 Phase	
FLA	-
MCA	-
MOC	-

230 Volt 3 Phase	
FLA	89
MCA	98
MOC	132

460 Volt 3 Phase	
FLA	45
MCA	50
MOC	65

Dimensions <sup>1</sup>	57"W x 79"L x 81"H
Frame	Powder Coated Steel
Housing	Powder Coated Aluminum
Tank	N/A
Compressor HP	10 (x2)
Condenser	Air-Cooled
Glycol Pump HP	1.5
Glycol Connection Size	1.5" FPT
Heat Exchanger	Stainless Steel Brazed Plate
Controls	Multi Stage Digital

Electrical Enclosure	NEMA 3R
Shipping Weight	2110 lbs
Decibels @ 10'	66
Refrigerant	R404a

*Cooling Capacity by Leaving Fluid Temperature<sup>2</sup>*

LFT	Btu/H	kW
20 °F	128,436	37.6
30 °F	158,744	46.5
40 °F	192,990	56.6

<sup>1</sup> Dimensions accurate for package chiller, remote condenser options will vary

<sup>2</sup> All capacities at 90 °F ambient

### Expansion module chiller package consists of the following:

- Complete refrigeration circuits
- Air-cooled condenser
- Chiller pump
- Freeze stat safety switch
- All insulated copper piping
- Powder coated steel frame
- Powder coated aluminum housing
- Engineered high efficiency heat exchanger for maximum energy savings
- Digital temperature controller pre-wired for integration into expanding system
- ETL (UL508) listed complete control panel with single point electrical connection breakers, starters & safety switches
- Brass ball valves for glycol supply and return connections
- Louvered aluminum access panels for easy service & maintenance
- Factory run tested and fully charged with refrigerant

**1 Year Parts and Labor Warranty**

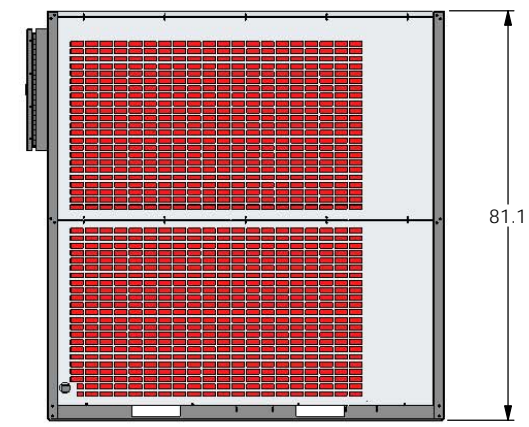
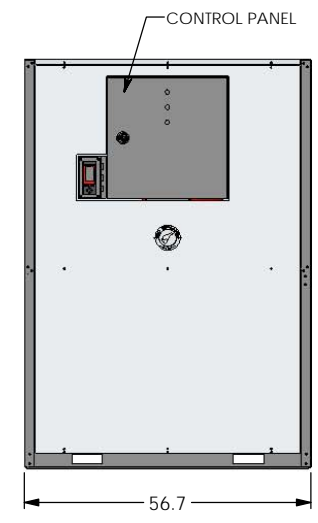
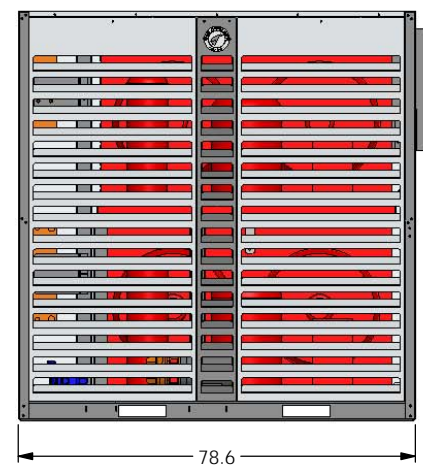
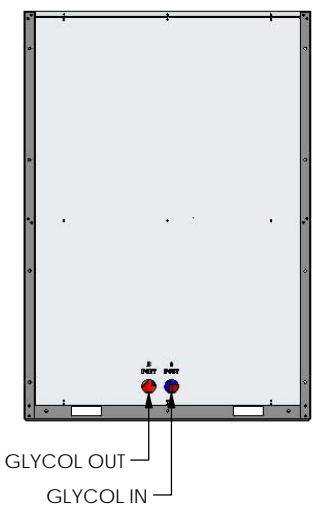
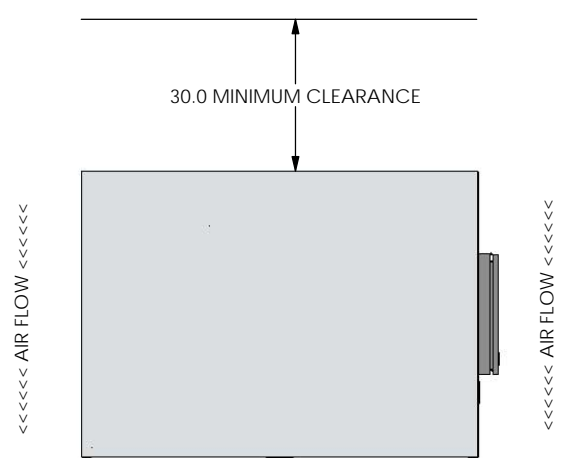

# GD-20H-EM EXPANSION MODULE



COMMITTED TO COLD  
EST 1993

760 BAILEY HILL ROAD EUGENE, OR 97402 - TEL (541) 345-3903 (800) 555-0973