



CHILLER MODEL: GD-5H-EM

230 Volt 1 Phase	
FLA	44
MCA	52
MOC	80

230 Volt 3 Phase	
FLA	30
MCA	35
MOC	50

460 Volt 3 Phase	
FLA	13
MCA	16
MOC	25

Dimensions ¹	34"W x 61"L x 49"H
Frame	Powder Coated Steel
Housing	Powder Coated Aluminum
Tank	N/A
Compressor HP	5
Condenser	Air-Cooled
Glycol Pump HP	3/4
Glycol Connection Size	1" FPT
Heat Exchanger	Stainless Steel Brazed Plate
Controls	Multi Stage Digital

Electrical Enclosure	NEMA 3R
Shipping Weight	1150 lbs
Decibels @ 10'	65
Refrigerant	R404a

Cooling Capacity by Leaving Fluid Temperature²

LFT	Btu/H	kW
20 °F	32,717	9.6
30 °F	40,850	12.0
40 °F	49,965	14.6

¹ Dimensions accurate for package chiller, remote condenser options will vary

² All capacities at 90 °F ambient

Expansion module chiller package consists of the following:

- Complete refrigeration circuit
- Air-cooled condenser
- Chiller pump
- Freeze stat safety switch
- All insulated copper piping
- Powder coated steel frame
- Powder coated aluminum housing
- Engineered high efficiency heat exchanger for maximum energy savings
- Digital temperature controller pre-wired for integration into expanding system
- ETL (UL508) listed complete control panel with single point electrical connection breakers, starters & safety switches
- Brass ball valves for glycol supply and return connections
- Louvered aluminum access panels for easy service & maintenance
- Factory run tested and fully charged with refrigerant

2 Year Parts and 1 Year Labor Warranty

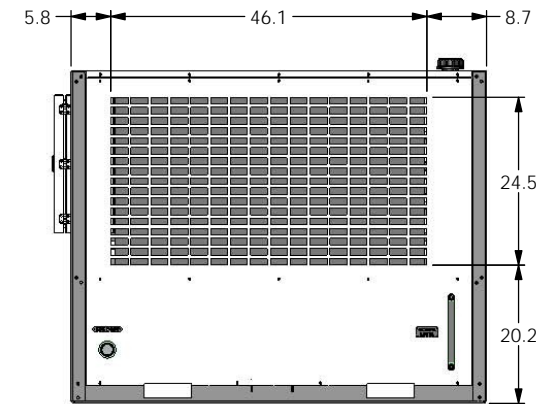
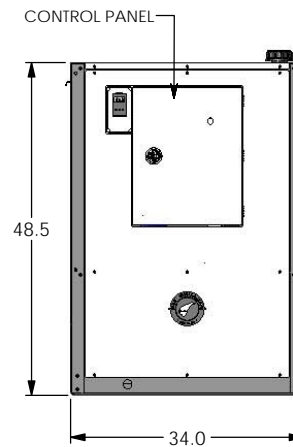
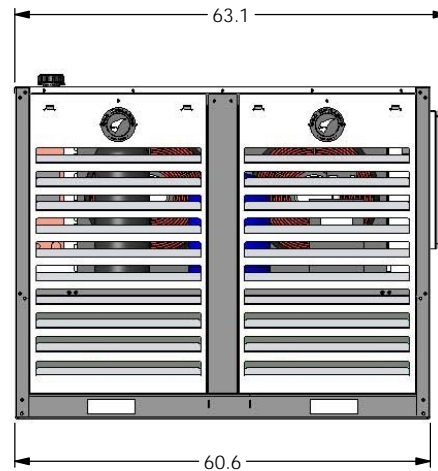
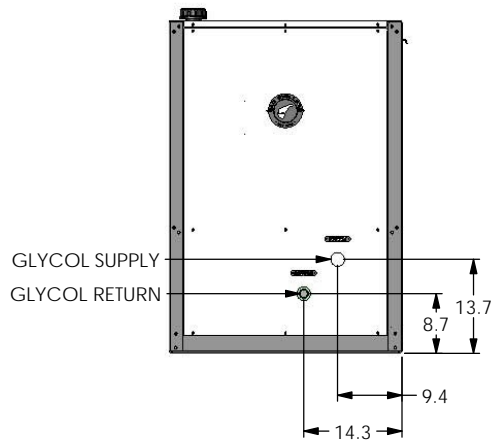
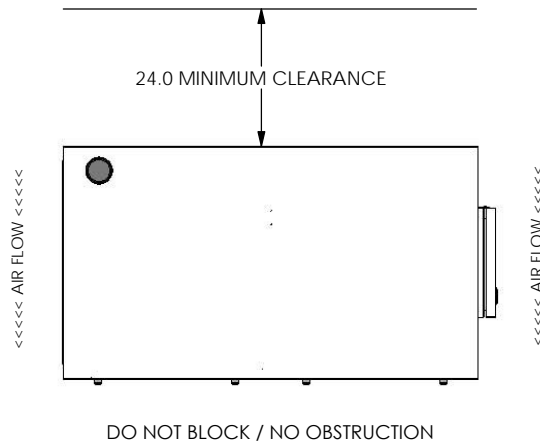
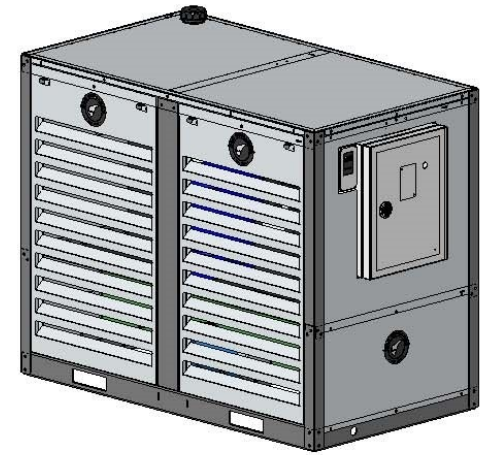

GD-5/7H-EM EXPANSION MODULE



G&D CHILLERS

COMMITTED TO COLD

○ EST 1993 ○

760 BAILEY HILL ROAD EUGENE, OR 97402 · TEL (541) 345-3903 (800) 555-0973