



CHILLER MODEL: GD-40H-2LC-VA2

230 Volt 1 Phase	
FLA	-
MCA	-
MOC	-

230 Volt 3 Phase	
FLA	177
MCA	196
MOC	273

460 Volt 3 Phase	
FLA	85
MCA	94
MOC	131

Dimensions ¹	45"W x 140"L x 102"H
Frame	Powder Coated Steel
Housing	Powder Coated Aluminum
Tank	90 Gallon Stainless Steel
Compressor	20 HP Two-Stage Recip (x2)
Condenser	Air-Cooled Vertical Discharge
Process Pump	5 HP
Flow Rate	30 GPM @ 25 PSI
Connection Size	1.5" CTS Flange
Heat Exchanger	Stainless Steel Brazed Plate
Controls	Microprocessor w/ Comm.

Electrical Enclosure	NEMA 3R
Refrigerant	R404a

Cooling Capacity by Leaving Fluid Temperature²

LFT	Btu/H	kW
-50 °F	76,900	22.5
-40 °F	102,600	30.1
-30 °F	135,000	39.6

¹ Dimensions accurate for package chiller, remote condenser options will vary

²All capacities at 90 °F ambient

Chiller package consists of the following:

- Two complete refrigeration circuits
- Air-cooled condenser
- Coolant pump
- Fluid bypass valve
- Freeze stat safety switch
- CTS flange coolant connections
- All insulated copper piping
- Powder coated steel frame
- Powder coated aluminum housing
- Semi-hermetic two-stage reciprocating compressors with subcoolers
- Engineered high efficiency heat exchanger for maximum energy savings
- Heavily insulated stainless steel coolant reservoir
- Microprocessor controller with communication
- ETL (UL508) listed complete control panel with single point electrical connection, breakers, starters & safety switches
- Louvered aluminum access panels for easy service & maintenance
- Factory run tested and fully charged with refrigerant

2 Year Parts and 1 Year Labor Warranty

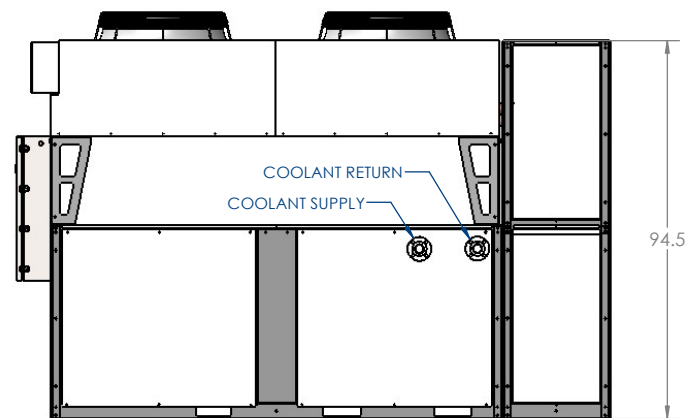
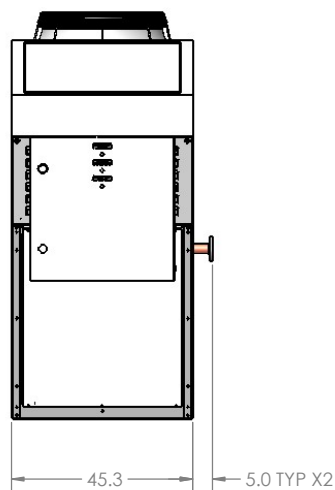
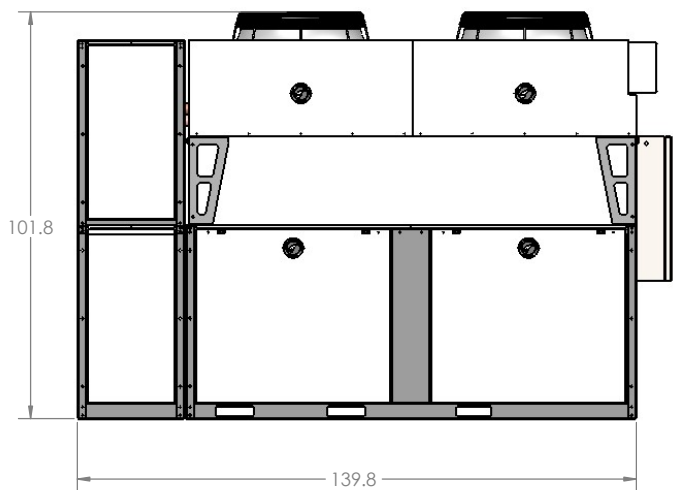
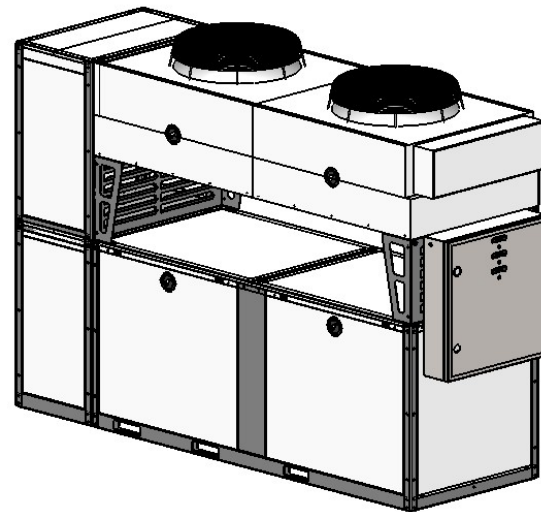
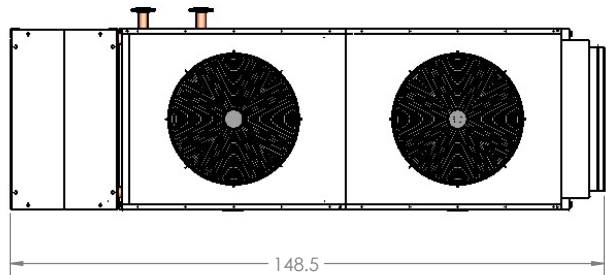

GD-40H-2LC

LOW TEMPERATURE CHILLER



G&D CHILLERS

COMMITTED TO COLD

EST 1993

760 BAILEY HILL RD, EUGENE, OR 97402 - TEL (541) 345-3903 (800) 555-0973