



CHILLER MODEL: GD-10CWS-PW

230 Volt 1 Phase	
FLA	6.2
MCA	15
MOC	15

230 Volt 3 Phase	
FLA	-
MCA	-
MOC	-

460 Volt 3 Phase	
FLA	-
MCA	-
MOC	-

Dimensions	30"W x 30"L x 30"H
Frame	Powder Coated Steel
Housing	Powder Coated Aluminum
Tank	N/A
Compressor	N/A
Condenser	N/A
Water Pump	3/4 HP
GPM @ 25 PSI	33
Water Inlet Connection	1-1/4" FPT
All Other Connections	1" FPT
Heat Exchanger	Double-Walled Brazed Plate

Controls	Single Stage Digital
Electrical Enclosure	NEMA 3R
Shipping Weight	440 lbs
Heat Transfer Rate ¹	120,000 Btu/h

¹ Rating based on 24 gpm water, 70 °F in, 60°F out, using 25.5 gpm glycol at 50 °F

Cold Water Skid package consists of the following:

- Water pump with optional VFD
- Digital temperature controller
- All insulated copper piping
- Supply & return water connections
- Supply & return glycol connections
- Powder coated steel frame
- Powder coated aluminum housing
- Engineered high efficiency heat exchanger rated for potable water
- Fluid bypass valve (shipped loose)
- ETL (UL508) listed complete control panel with single point electrical connection, breakers, starters & safety switches
- Louvered stainless steel access panels for easy service & maintenance
- Factory run tested

2 Year Parts and 1 Year Labor Warranty

DETAIL A
SCALE 1:3

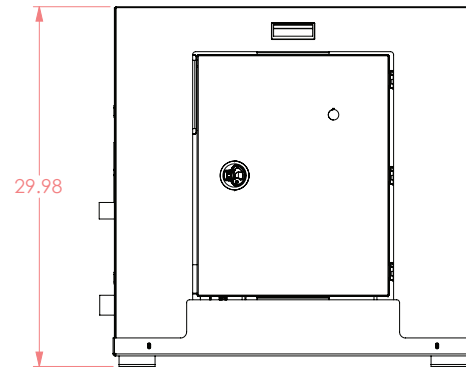
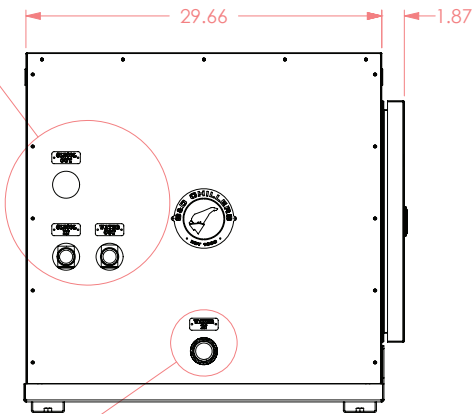
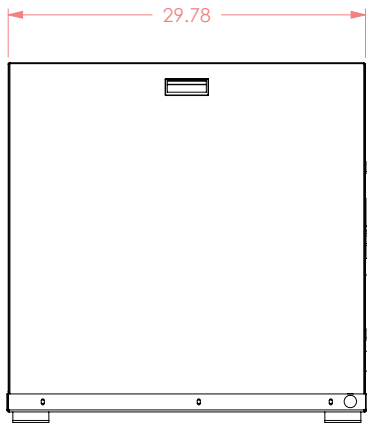
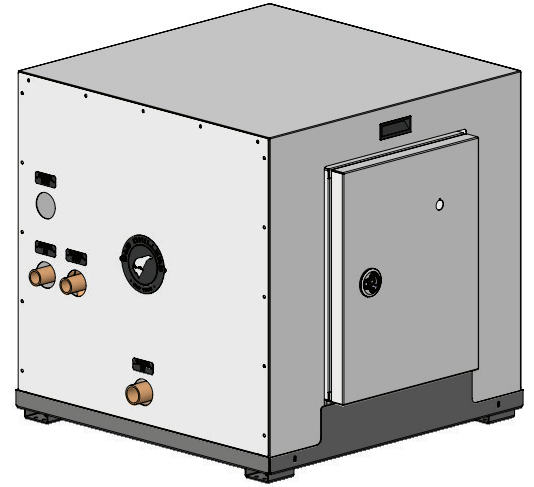
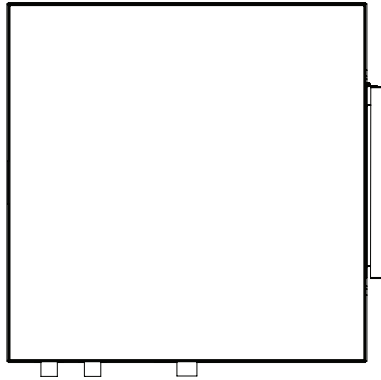
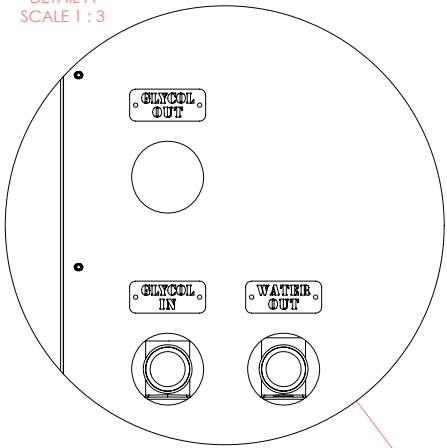

DETAIL B
SCALE 1:3



GD-10CWS-PW
COLD WATER STORAGE SKID



G&D CHILLERS

COMMITTED TO COLD

EST 1993

760 BAILEY HILL ROAD EUGENE, OR 97402 - TEL (541) 345-3903 (800) 555-0973