



## CHILLER MODEL: GD-200H-4C

208-240V 1-Phase	
FLA	-
MCA	-
MOC	-

208-240V 3-Phase	
FLA	-
MCA	-
MOC	-

460-480V 3-Phase	
FLA	451
MCA	476
MOC	500

Dimensions <sup>1</sup>	96"W x 328"L x 120"H
Frame	Powder Coated Steel
Housing	Powder Coated Aluminium
Tank	1400 Gallon Stainless Steel
Compressor	50 HP (x4)
Condenser	Air-Cooled Vertical Discharge
Process Pump	15 HP
Process Flow	470 GPM @ 25 PSI
Connection	6" CTS Flange
Chiller Pump	3 HP (x2)
Heat Exchanger	Stainless Steel Brazed Plate
Controls	Microprocessor w/ Comm.

Electrical Enclosure	NEMA 3R
Ship/Operating Weight	16000/28500 lbs
Decibels @ 10'	83 dBA
Refrigerant	R454C

### Cooling Capacity by Leaving Fluid Temperature<sup>2</sup>

LFT	Btu/H	kW
20 °F	996,900	292.2
30 °F	1,213,900	355.8
40 °F	1,450,000	425.0

1. Package chiller dimensions, remote condenser options will vary

2. Capacity based on a 10°F temperature difference and 90°F ambient temperature at 0' ASL

3. Specifications subject to change without notice

### Chiller package consists of the following:

- Four complete refrigeration circuits
- Air-cooled condenser
- Process pump with VFD
- Two chiller pumps
- Fluid bypass valve
- All insulated copper piping
- ASME B16.5 flange connections
- Powder coated frame and housing
- Semi-hermetic reciprocating compressors with capacity unloading
- Engineered high efficiency heat exchangers for maximum energy savings
- Insulated stainless steel glycol reservoir with baffle plate
- Microprocessor controller with communication capabilities
- ETL (UL 508A) listed complete control panel with single point electrical connection, breakers, starters & safety switches
- Removable access panels for easy service & maintenance
- Factory run tested and fully charged with refrigerant

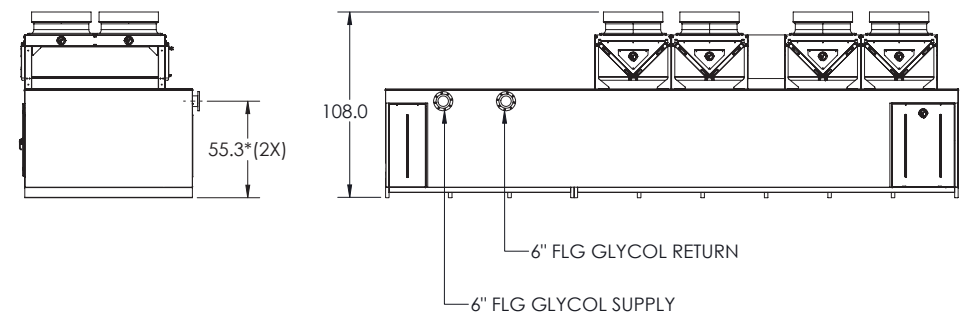
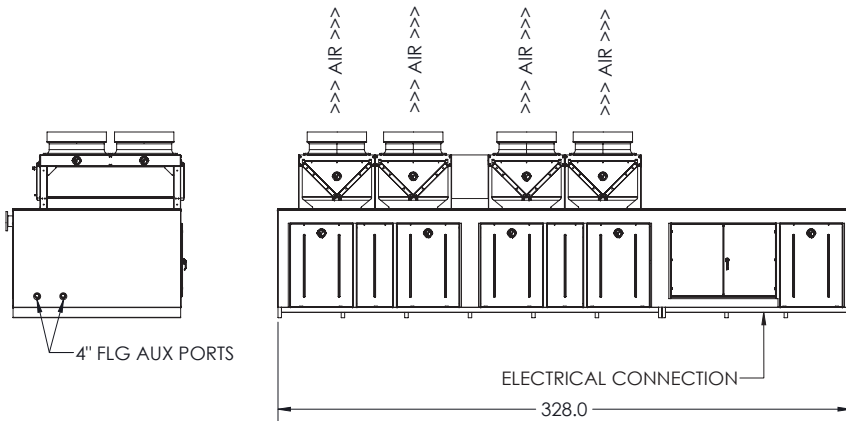
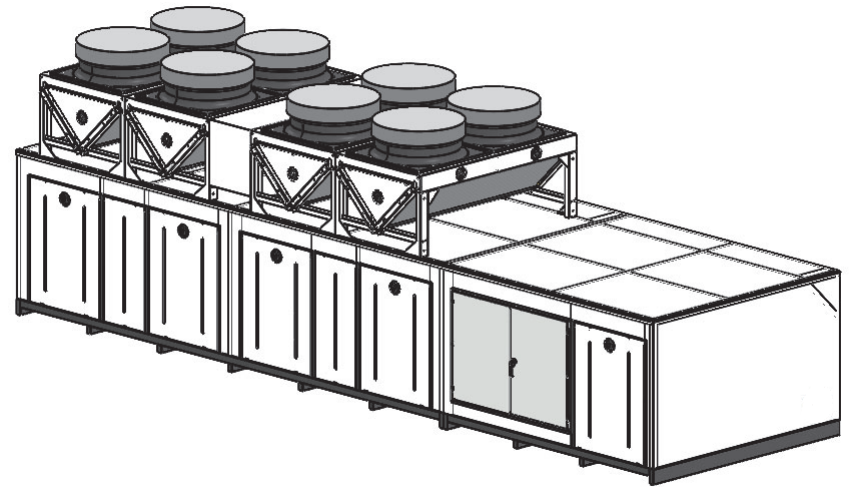
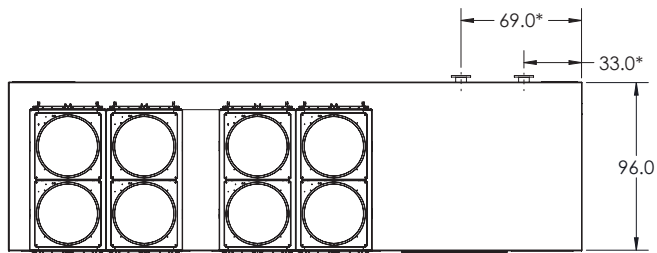

1. ASTERISK \* INDICATES APPROXIMATE DIMENSIONS, DO NOT USE TO PREFABRICATE CONNECTING PIPING
2. ENSURE A MINIMUM OF 8 FT CLEARANCE AROUND ALL SIDES OF UNIT
3. UNIT MUST BE SECURELY ANCHORED TO A FLAT AND LEVEL PAD
4. ALL DIMENSIONS MEASURED IN INCHES
5. INSTALATION OF ELECTRICAL SERVICE
  - A. POWER WIRING TO TERMINATE AT DISTRIBUTION BLOCKS INSIDE ENCLOSURE
  - B. PENETRATIONS TO BE DRILLED IN FIELD BY OTHERS THROUGH BOTTOM OF ENCLOSURE
  - C. USE ONLY CONDUIT/FITTINGS WITH SAME (OR HIGHER) ENVIRONMENTAL RATING AS ENCLOSURE
  - D. FIELD-INSTALLED EXTERNAL DISCONNECT TO BE PROVIDED BY OTHERS

# GD-200H-4C

## VERTICAL AIR CHILLER

DRAWN:	LL
APPROVED:	TH
DATE:	03/20/26



**G&D CHILLERS**  
COMMITTED TO COLD

130 E FIRST AVE, JUNCTION CITY, OR 97448  
TEL: (541) 345-3903 (800) 555-0973