



PORTABLE CHILLER MODEL: CH-5

230 Volt 1 Phase	
FLA	47
MCA	55
MOC	87

230 Volt 3 Phase	
FLA	29
MCA	34
MOC	53

460 Volt 3 Phase	
FLA	15
MCA	18
MOC	27

Dimensions	34"W x 61"L x 57"H
Frame	Powder Coated Steel
Housing	Stainless Steel
Tank	50 Gallon Stainless Steel
Compressor	5 HP
Condenser	Air-Cooled
Glycol Pump	1.5 HP
Process Flow	40 GPM @ 25 PSI
Connection Size	0.75" Brass Quick Connects (x5)
Heat Exchanger	Stainless Steel Brazed Plate
Controls	Single Stage Digital

Electrical Enclosure	NEMA 3R
Ship/Operating Weight	1000/1450 lbs
Decibels @ 10'	65 dBA
Refrigerant	R448A

Cooling Capacity by Leaving Fluid Temperature¹

LFT	Btu/H	kW
20 °F	32,700	9.6
30 °F	41,100	12.0
40 °F	50,600	14.8

1. All capacities at 90°F ambient

2. Specifications subject to change without notice

Portable chiller package consists of the following:

- Complete refrigeration circuit
- Air-cooled condenser
- Glycol pump
- Fluid bypass valve
- Freeze stat safety switch
- Digital temperature controller
- All insulated copper piping
- Stainless steel housing
- Powder coated steel frame
- Engineered high efficiency heat exchanger for maximum energy savings
- Insulated stainless steel glycol reservoir
- Heavy duty rubber-on-steel casters for easy portability
- Brass quick connects for cooling up to 5 tanks at once without loss of glycol
- One set of 20 ft. glycol hoses and 25 ft. power cord
- ETL (UL508) listed complete control panel with single point electrical connection, breakers, starters & safety switches
- Louvered stainless steel access panels for easy service & maintenance
- Factory run tested and fully charged with refrigerant

2 Year Parts and 1 Year Labor Warranty

GLYCOL FILL

24.0 MINIMUM CLEARANCE

←←←← AIRFLOW ←←←←

←←←← AIRFLOW ←←←←

DO NOT BLOCK / NO OBSTRUCTION

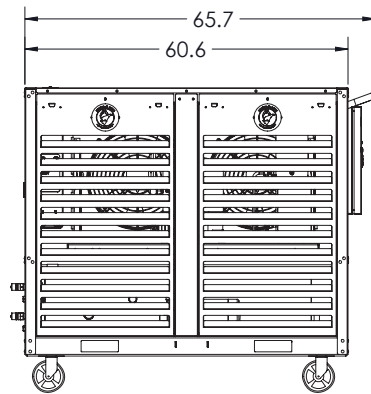
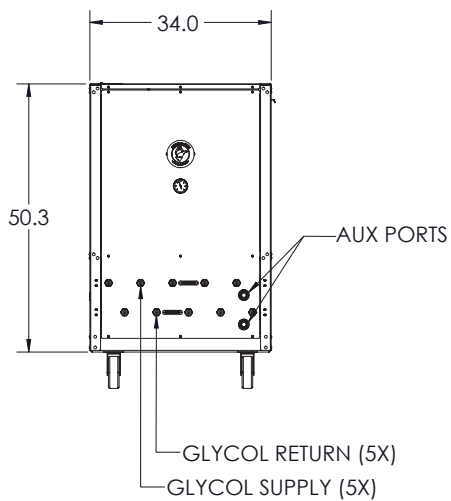
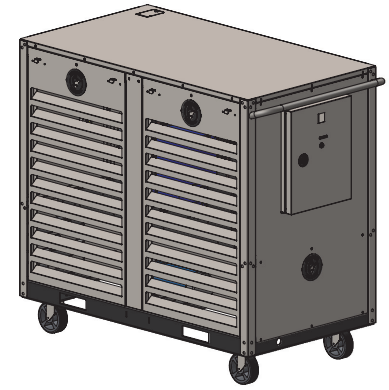

CONTROL PANEL

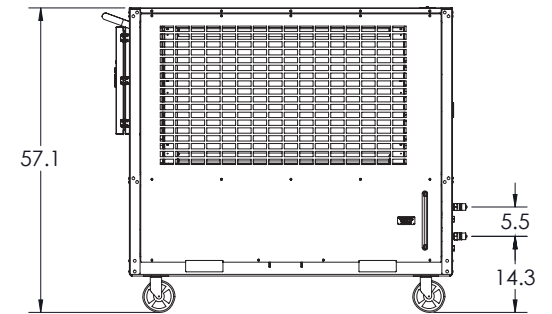
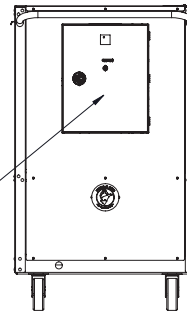

CH-5 / CH-7

PORTABLE CHILLER

DRAWN:	AH
APPROVED:	TH
REVISION DATE:	05/11/23



G&D CHILLERS
COMMITTED TO COLD

130 E FIRST AVE, JUNCTION CITY, OR 97448
TEL: (541) 345-3903 (800) 555-0973