



CHILLER MODEL: GD-13.5H-EM

230 Volt 1 Phase	
FLA	-
MCA	-
MOC	-

230 Volt 3 Phase	
FLA	56
MCA	67
MOC	112

460 Volt 3 Phase	
FLA	29
MCA	35
MOC	55

Dimensions ¹	48"W x 73"L x 61"H
Frame	Powder Coated Steel
Housing	Powder Coated Aluminum
Tank	N/A
Compressor	13.5 HP
Condenser	Air-Cooled Microchannel
Glycol Pump	1 HP
Glycol Connection Size	1.5" FPT
Heat Exchanger	Stainless Steel Brazed Plate
Controls	Multi Stage Digital

Electrical Enclosure	NEMA 3R
Shipping Weight	1600 lbs
Decibels @ 10'	66 dBA
Refrigerant	R448A

Cooling Capacity by Leaving Fluid Temperature²

LFT	Btu/H	kW
20 °F	77,900	22.8
30 °F	95,100	27.9
40 °F	114,200	33.5

1. Package chiller dimensions, remote condenser options will vary

2. All capacities at 90 °F ambient

3. Specifications subject to change without notice

Expansion module chiller package consists of the following:

- Complete refrigeration circuits
- Air-cooled condenser
- Chiller pump
- Freeze stat safety switch
- All insulated copper piping
- Powder coated steel frame
- Powder coated aluminum housing
- Engineered high efficiency heat exchanger for maximum energy savings
- Digital temperature controller pre-wired for integration into expanding system
- ETL (UL508) listed complete control panel with single point electrical connection breakers, starters & safety switches
- Brass ball valves for glycol supply and return connections
- Louvered aluminum access panels for easy service & maintenance
- Factory run tested and fully charged with refrigerant

2 Year Parts and 1 Year Labor Warranty

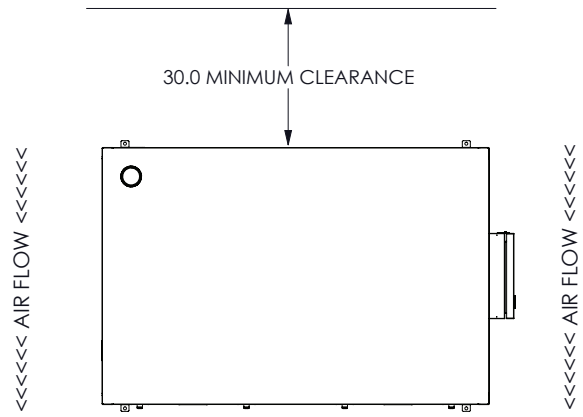
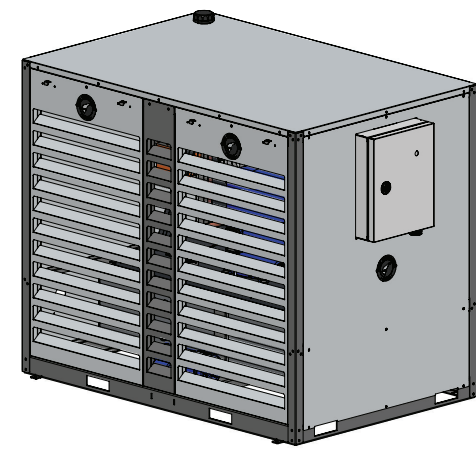

EXHAUST SIDE: DO NOT BLOCK / NO OBSTRUCTION

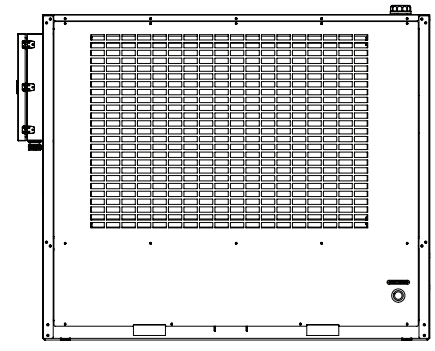
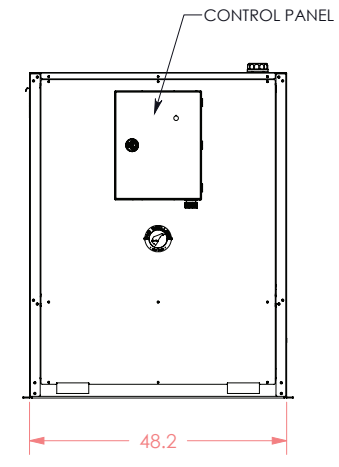
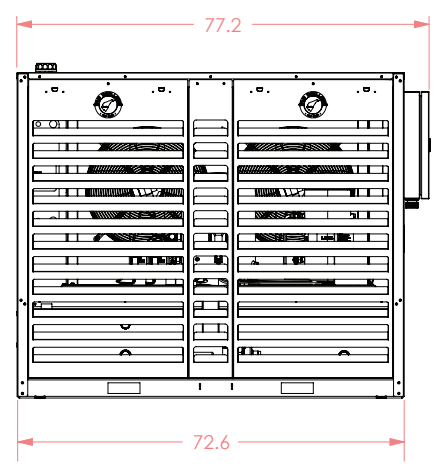
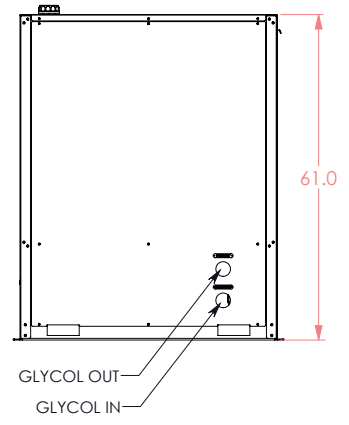

GD-10H / 13.5H-EM EXPANSION MODULE



COMMITTED TO COLD
◦ EST 1993 ◦

760 BAILEY HILL RD, EUGENE, OR 97402 - TEL (541) 345-3903 (800) 555-0973