



## CHILLER MODEL: GD-50H-1C-EM

230 Volt 1 Phase	
FLA	-
MCA	-
MOC	-

230 Volt 3 Phase	
FLA	215
MCA	263
MOC	455

460 Volt 3 Phase	
FLA	107
MCA	131
MOC	227

Dimensions <sup>1</sup>	46"W x 167"L x 108"H
Frame	Powder Coated Steel
Housing	Powder Coated Aluminum
Tank	N/A
Compressor	50 HP
Condenser	Vertical Discharge Air-Cooled
Glycol Pump	2 HP
Glycol Connection Size	2" Female NPT
Heat Exchanger	Stainless Steel Brazed Plate
Controls	Multi Stage Digital

Electrical Enclosure	NEMA 3R
Shipping Weight	5100 lbs
Decibels @ 10'	77 dBA
Refrigerant	R448A

### *Cooling Capacity by Leaving Fluid Temperature<sup>2</sup>*

LFT	Btu/H	kW
20 °F	315,000	92.3
30 °F	387,000	113.4
40 °F	468,000	137.2

1. Package chiller dimensions, remote condenser options will vary

2. All capacities at 90 °F ambient

3. Specifications subject to change without notice

### ***Expansion module chiller package consists of the following:***

- Complete refrigeration circuit
- Air-cooled condenser
- Chiller pump
- Freeze stat safety switch
- All insulated copper piping
- Female NPT glycol connections
- Powder coated steel frame
- Powder coated aluminum housing
- Semi-hermetic reciprocating compressor with capacity unloading
- Engineered high efficiency heat exchanger for maximum energy savings
- Digital temperature controller pre-wired for integration into expanding system
- ETL (UL508) listed complete control panel with single point electrical connection breakers, starters & safety switches
- Louvered aluminum access panels for easy service & maintenance
- Factory run tested and fully charged with refrigerant

***2 Year Parts and 1 Year Labor Warranty***

REVISIONS				
ZONE	REV.	DESCRIPTION	DATE	APPROVED

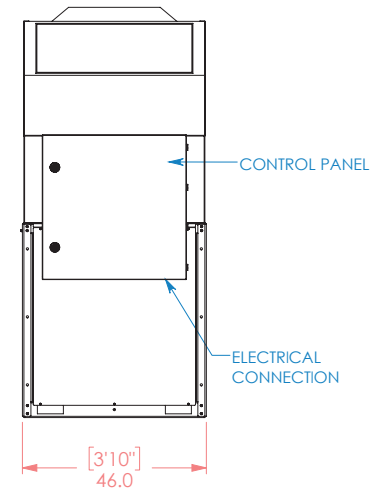
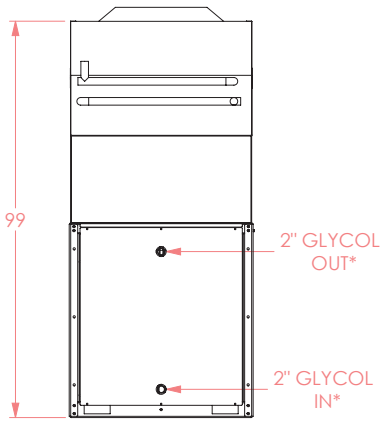
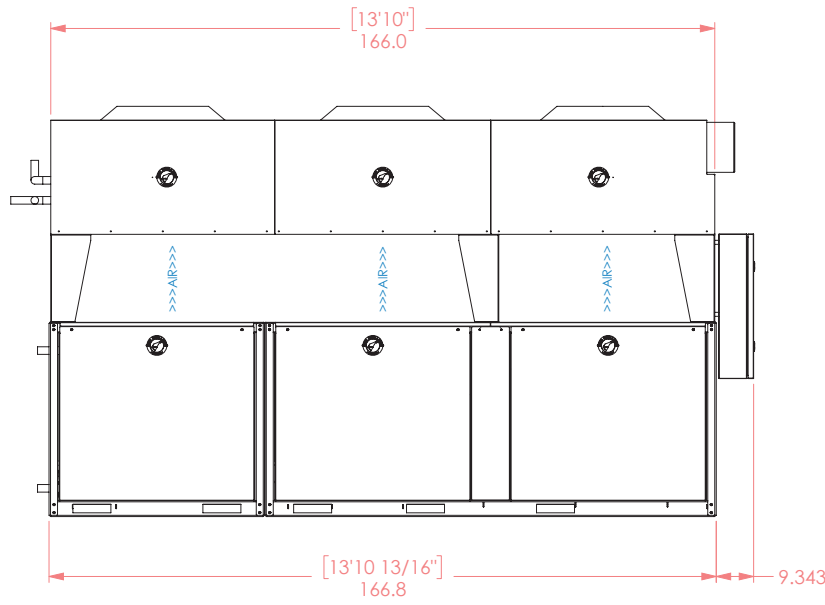
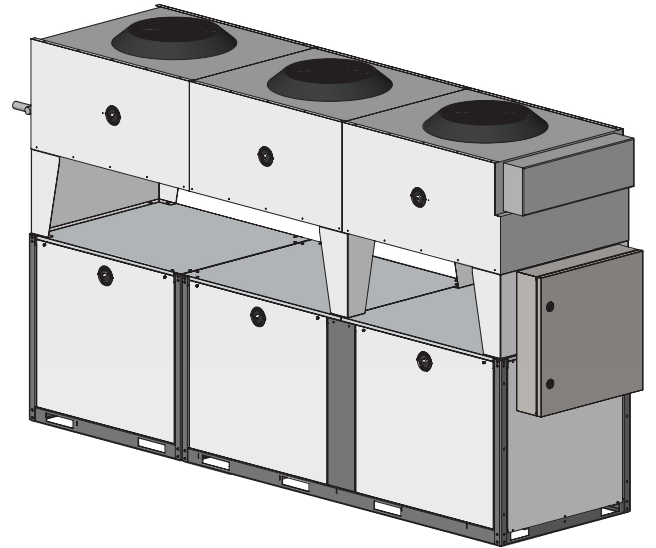
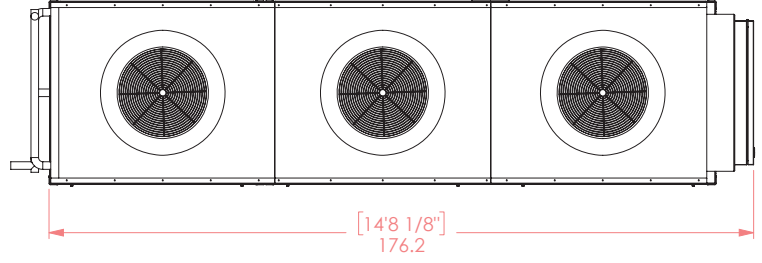

\*GLYCOL CONNECTION LOCATIONS FOR GENERAL REFERENCE ONLY  
PRECISE LOCATIONS MAY VARY

# GD-50H-1 C-EM

## VERTICAL AIR CHILLER



**G&D CHILLERS**

COMMITTED TO COLD  
o EST 1993 o

760 BAILEY HILL ROAD EUGENE, OR 97402 - TEL (541) 345-3903 (800) 555-0973